

Dear Clients: Thanks for choosing IBEST TCN SERIES Temperature Controller! Before installing and using this product, please read this user manual carefully in order to operate the unit in the appropriate conditions to avoid any damage. Keep this user manual for future reference.

CAUTIONS

- ELECTRICAL CONNECTION CAUTIONS:
 - a. When the controller occurs error, the system might get into malfunction, the users need to configure external protection circuit to avoid the accident.
 - b. To protect the controller from damage or invalidation, please select the appropriate fuse to protect the power supply cable and the in/out cable to prevent current impact.
- CONTROLLER POWER SUPPLY
 - a. The controller supply is 85-264V AC, working beyond the stated supply might cause damage or invalidation to the controller
 - b. Make sure all connections must be done before POWER ON.
- Do not operate the controller in flammable, explosive gas and vapor environment.
- Do not touch the controller internal parts:

There are high-voltage and high-temperature parts inside the controller, it is dangerous for the user to touch the parts. If there are any quality questions, please contact with our sales people or technical people for assistance.
- To modify to controller by the user is prohibited to avoid damage or accident.
- Maintenance
 - a. Users are prohibited to repair the controller by themselves to avoid any damage to the controller
 - b. The controller needs to check and maintain regularly so as to operate safely long-term. To change the damaged components, please contact our sales people or technical people for assistance.
- CAUTIONS:
 - a. When clean the instrument, make sure the power is at "OFF" status.
 - b. To clean out the dust or dirt on the instrument screen, please use soft cloth or cotton paper.
 - c. Do not touch the instrument screen by hard objects to avoid scratch of the screen.
 - d. Do not use screw driver or hard pin to touch the soft buttons on the faceplate.

1. FEATURES

- PID temperature controller or ON/OFF control; built with SMT technology
- Auto tune function, fuzzy PID, Cooling/heating function.
- Dual line 4 LED digit display: upper LED: red; lower LED: green
- Soft buttons, easily operate
- Optional input signals: thermocouple: K, S, E, J, T, B; thermo resistance: Pt100, Cu50,
- Optional control output: Relay, SSR (Logic), SCR or Linear output.
- 2 alarm output
- Measuring accuracy: : $\pm 0.5\%F.S \pm 1$ digit (under normal conditions)
- Optional instrument size: 48W×48H; 48W×96H; 72W×72H; 96W×48H; 96W×96H. (mm)
- Application ranges: food&beverage; oven, furnace, plastic extruder, chemicals processing, heating process...etc. (For temperature measuring and control)

Implementos Industriales
 Medición y Control de Temperatura
 Humedad - Caudal
 Nivel y Llama
www.implementosenlaweb.com.ar
 Tel.: (0351) 4805405

2. ORDERING CODE

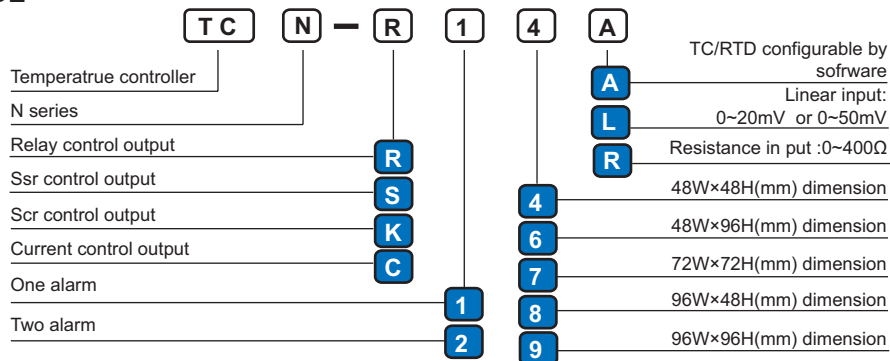

3. TECHNICAL SPECIFICATIONS

INPUT TYPE	A	TC/RTD configurable by software	Thermocouple	K	0~1300℃	S	0~1600℃
				E	0~600℃	T	0~300.0℃
				J	0~800℃	B	200~1800℃
			Thermo resistance	Pt100			-200~800℃
				Cu50			-50~150℃
	L	Linear input	0~20mV or 0~50mV or 0~400Ω				
	R	Resistance input	0~400Ω				
CONTROL OUTPUT		Relay	240V AC /3A				
		Ssr	Logic(SSR) output 12VDC/30mA				
		Scr	Scr out put				
		Current	0~10mA or 4~20mA				
CONTRON TYPE	ON/OFF control / PI control / fuzzy PID						
MEASURING ACCURACY	0.5%±1 digit						
OPERATION CONDITION	0~50℃ /45~85RH%/86~106KPa						
INSULATION STRENGTH	AC 1500V 1 min / DC500V ≥50MΩ						
POWER SUPPLY	85~260V AC 50~60HZ						
DIMENSIONS	4:48W×48H / 6:48W×96H/ 7:72W×72H/ 8:96W×48H/9:96W×96H						

IBEST ELECTRICAL CO.,LTD

Medición y Control de Temperatura
 Humedad - Caudal
 Nivel y Llamo
Implementos Industriales
 www.implementosenlaweb.com.ar
 Tel.: (0351) 4805405

4. PANEL ILLUSTRATION



5. ELECTRICAL CONNECTIONS

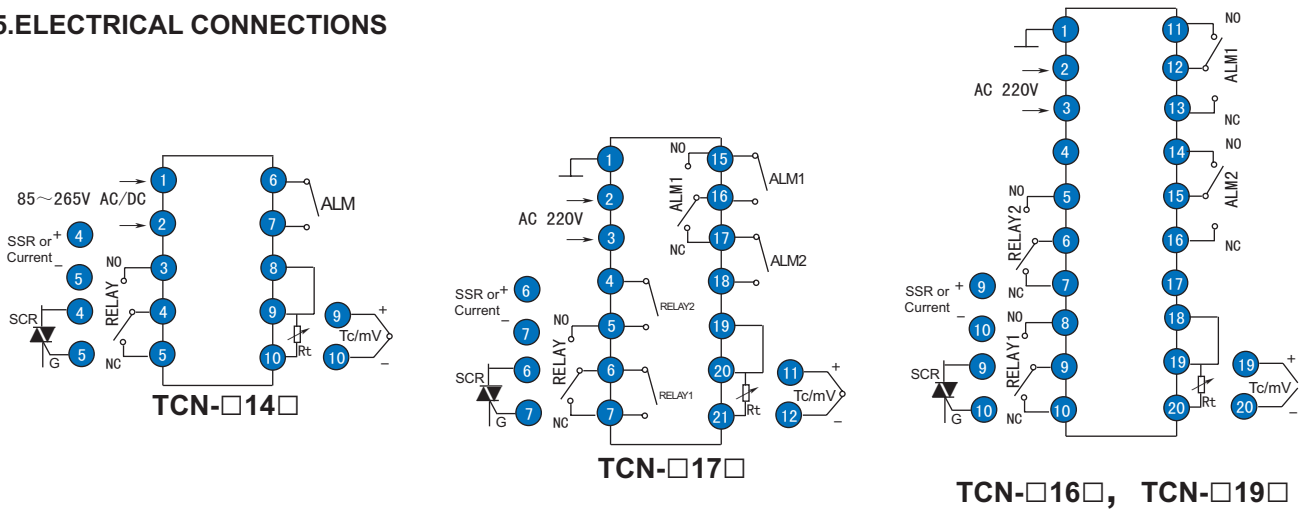

6. OPERATION ILLUSTRATION

a. Input Signals

CODE	INP	Measuring range
tc-s	S	0~1600℃
tc-b	B	200~1800℃
tc-k	K	0~1300℃
tc-e	E	0~600℃
tc-t	T	0~300.0℃
tc-j	J	0~800℃
Pt-H	Pt100	-200~800℃
Cu50	Cu50	-50~150℃
u20	0~20mV	
u50	0~50mV	
400r	0~400Ω	

b. Process operation

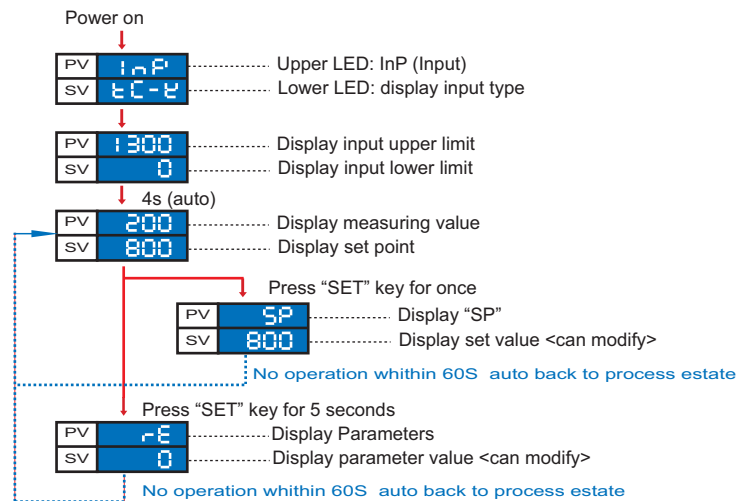

c. Parameter function instructions:

Set Point

Press "SET" key, the upper LED display "SP"; lower LED display set point, press "▲" or "▼" to modify the value you need. Then confirm the value by press "SET" key again.

Control parameters

Press "SET" key for 5 seconds, the upper LED display the control parameters, the lower LED display the parameters value. To modify the parameters value, please press "▲" and "▼" key. Press "SET" key to confirm the value modified and then press "SET" key to shift to the next parameter. If you want to escape the control parameters menu, please press "SET" key for 5 seconds; or no operation within 60s also let the controller go back to measuring estate. The parameters list, please refer to page "P3"

Auto-tune function

- Press "▲" for 20 seconds, "AT" lamp flashing, the controller start "auto-tune"; when "auto-tune" finish, "AT" lamp goes out. The controller will get new P, I, D value that makes the temperature rise quickly;
- Press "▼" key for 20s, "AT" lamp flashing, the controller start "auto-tune"; when "auto-tune" finish, "AT" lamp goes out. The controller will get new P, I, D value that can restrain exceeding temperature range.
- The new P, I, D parameter value can be found in the controller (menu).
- In case user want to escape in the middle course of "Auto-tune", press "▲" or "▼" key for 20s, "AT" lamp will goes out, "Auto-tune" is stopped. The controller works on its original P, I, D value.

Notice If the upper LED display "0000", it means the input signal exceeds the measuring range or the sensor open circuit.

d. Menu of control parameters

PARAMETER	NAME	SPECIFICATIONS	RANGE	FACTORY SETTING
rE rE	Proportion control modification	When I=0, Proportion control modification functions; (used for static deviate of adjustable Proportion control)	-99~100℃	0
rE rt	Process value deviate	Measuring value compensation, used for correct deviate caused by sensor or sensor compensation cable.	-99~100℃	0
dF dF	Dead zone	Used for control dead zone, function when P/d=0; used for dead zone of adjustable ON/OFF control)	0.4~100℃	0.4
AL1 AL1	Alarm 1 output	Set Alarm 1 output value, alarm dead zone is 0.4(fixed)	Measure range	Max. value
AL2 AL2	Alarm 2 output	Set Alarm 2 output value, alarm dead zone is 0.4(fixed)	Measure range	Max. value
P P	Proportion band (heating)	When "P" is bigger, the proportion is less function, the system gain is lower. (Only for heating function, P=0, ON/OFF control)	0~300℃	30
I I	Integral time	The bigger "I" is, the weaker integral functions; I=0, means PD control	0...3600s	240
D D	Derivative time	The bigger "D" is, the stronger Derivative functions and can restrain exceeding temperature range. D=0 ,means PI control	0...3600s	60
T T	Control cycle (heating)	Relay output<20s; SSR/SCR output<2s; Linear output=1s (only for heating function)	1~100s	30
Pc Pc	Proportion band (Cooling)	When "P" is bigger, the proportion is less function, the system gain is lower. (Only for cooling function)	Percentage of Heating: 1~1000%	100
db db	(Between heating and cooling)	Non- superposition zone between Cooling and heating Proportion band)	-10~10 C	0
t t	Control cycle (Cooling)	Relay output<20s; SSR/SCR output<2s; Linear output=1s (only for cooling function)	1~100s	30
FILt FILt	Filter modulus (measuring value)	When Filter modulus is smaller, display reaction is sensitive, but liable to fluctuate; whereas display is more stable.	0~255	200
Lck Lck	Lock key	0: all parameters can be modified 1: only set point can be modified 2: all parameters can read only, can not be modified	0...2	0

7. DIMENSION AND INSTALLATION HOLE DIMENSION(unit: mm)

MODE	DIMENSION		INSTALLATION HOLE DIMENSION: a × b
	W × H	C × D × L	
TCN-□14□	48 × 48	44 × 44 × 100	45 × 45
TCN-□16□	48 × 96	44 × 92 × 100	45 × 93
TCN-□17□	72 × 72	68 × 68 × 100	69 × 69
TCN-□19□	96 × 96	92 × 92 × 100	93 × 93

8. CALIBRATION PARAMETERS

- a, Press both "▲" and "▼" key at the same time for 5s to enter into calibration parameters.
- b, First parameter is "LC", only set = 256 can go to next parameters. Please refer to following table. Press "↻" key to move from one parameter to next.

PARAMETER	NAME	SPECIFICATIONS	RANGE	FACTORY SETTING
LC LC	LOCK key	When LC=256, can enter into parameters; LC=other no., can't enter into parameters		0
InPt InPt	Input signals Select by press "▲" or "▼" key	0: "S" (TC) 1: "B" (TC) 2: "K" (TC) 3: "E" (TC) 4: "T" (TC) 5: "J" (TC) 6: "We-Re3-25" 7: "HPT100" 8: "LPT100" 9: "Cu50" 10: "20mV" (linear) 11: "50mV" (linear) 12: "400 ohm"	0, 0~1600℃ 1,200~1800℃ 2,0~1300℃ 3,0~600℃ 4,0~300℃ 5,0~800℃ 6,600~2000℃ 7,-200~800℃ 8,-200~200℃ 9,-50~150℃ 10,-1999~9999℃ 11,-1999~9999℃ 12,-1999~9999℃	2

IBEST ELECTRICAL CO.,LTD

OR	PID control function Select by press "▲" or "▼" key	0: No control 1: PID control (reverse function) 2: PID control (direct function) 3: Dual loop PID 4: PID control (direct function) continuous output		2
SA1	Alarm 1 output modes Select by press "▲" or "▼" key	0: No alarm output 1: High absolute value alarm 2: Low absolute value alarm 3: High deviation value alarm 4: Low deviation value alarm 5: Hi / Lo deviation value alarm (Hi and Lo deviation value are AL1) 6: Hi / Lo symmetrical deviation alarm with respect to the control setpoint (Hi and Lo deviation value are AL1) 7: Hi / Lo symmetrical absolute value alarm with respect to the control setpoint (Hi-AL2, Lo-AL1) 8: Hi / Lo symmetrical deviation alarm with respect to the control setpoint (Hi deviation-AL2, Lo-AL1) 9: Hi symmetrical absolute value and Lo symmetrical deviation alarm with respect to the control setpoint (Hi-AL2, Lo deviation-AL1) 10: Hi symmetrical deviation and Lo symmetrical absolute value alarm with respect to the control setpoint (Hi deviation-AL2, Lo-AL1) 11: Hi / Lo symmetrical absolute value alarm with respect to the control setpoint (Hi-AL2, Lo-AL1) 12: Hi / Lo deviation value alarm (hi deviation - AL2, Lo deviation - AL1)		2
SA2	Alarm 2 output modes Select by press "▲" or "▼" key	0: No alarm output 1: High absolute value alarm 2: Low absolute value alarm 3: High deviation value alarm 4: Low deviation value alarm 5: Hi / Lo deviation value alarm (Hi and Lo deviation value are AL2) 6: Hi / Lo symmetrical deviation alarm with respect to the control setpoint (Hi and Lo deviation value are AL2)		0
RAGL	Adjust measuring range Lo limit, select by press "▼" or "▲" key		With respect to probe	0
RAGH	Adjust measuring range Hi limit, select by press "▼" or "▲" key		With respect to probe	400
DP	Decimal point, select by press "▼" or "▲" key	0: 0000 1: 000.0 2: 00.00 3: 0.000		0

C, Till to the end of parameter "DP", press "↺" key, controller return to measuring estate.

e. Alarm output mode illustrations

Code	Alarm output mode	ALM1 and AL2 is independent alarm output	
		ALM 1 output	ALM 2 output
1	High absolute value alarm		
2	Low absolute value alarm		
3	High deviate alarm		
4	Low deviate alarm		
5	High/low deviate alarm		
6	(Hi and Lo)Symmetrical deviation alarm with respect to the control setpoint		
ALM1 and AL2 is used in combination, ALM1 output active, ALM2 output inactive			
7	(Hi and Lo)Symmetrical absolute value alarm with respect to the control setpoint (ALM2 output inactive)		
8	(Hi and Lo)Symmetrical deviation alarm with respect to the control setpoint (ALM2 output inactive)		
9	Hi Symmetrical absolute value alarm and Lo Symmetrical deviation alarm with respect to the control setpoint (ALM2 output inactive)		
A	Hi Symmetrical deviation alarm and Lo Symmetrical absolute value alarm with respect to the control setpoint (ALM2 output inactive)		
B	(Hi and Lo) Symmetrical absolute value alarm with respect to the control setpoint (ALM2 output inactive)		
C	(Hi and Lo) Symmetrical deviation alarm with respect to the control setpoint (ALM2 output inactive)		